

REVISIONS			
PRO REV	DATE	ALTERATION	AUTH
0	14-12-2019	AS PER CLIENT'S REQUEST	V1422

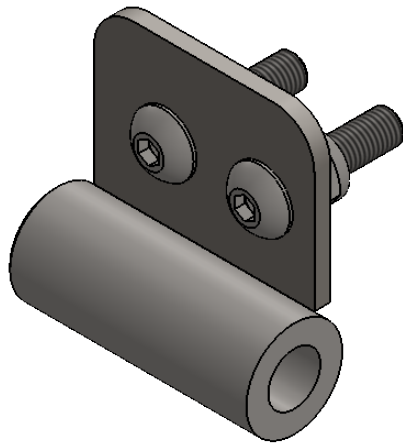

MO: 19110195	Batch: 1 of 1	Product Description: Barrel Hinge Female Part (S-Steel) Bolt on RH	0	14-12-2019	AS PER CLIENT'S REQUEST					V1422				
Quantity Batch: 10	Product Code: 001-005-0037NZ		PRO REV.	DATE	ALTERATION					AUTH.				
Contract #: N/A	Dwg Description: REVISIONTABLE		Selection	0.5-3	>3-6	>6-30	>30-120	>120-400	>400-1000	>1000-2000	>2000-4000	>4000-8000	Angle Tolerance	
Contract Ref: Reid&Twname - C52	Client: Reid&Twname	Client Code: N/A		±0.05	±0.05	±0.1	±0.15	±0.2	±0.3	±0.5	±0.8	-	±1°	
Issued By:	Date:	Client Dwg Ref: N/A	Client Rev: 0		±0.1	±0.1	±0.2	±0.3	±0.5	±0.8	±1.2	±2		±3
Received By:	Date:	Product Finish: MATTE		→	±0.15	±0.2	±0.5	±0.8	±1.2	±2	±3	±4		±5
NOTE: All dimensions in mm (unless noted otherwise)					W = 0.0 (Kg)			Sheet 1 of 3			First Angle Projection			

List of Part

Part #	Code	Description	Material Spec	Size	Qty.	Unit	Total
AC1	SFP-010-0167	Barrel Hinge Female Part (S-Steel) Bolt on RH	S-Steel	-	1	Pcs	1
AC2	914-098-0004	Stainless steel washer to suit M4 OD 10mm x 1mm	Stainless steel	-	2	Pcs	2
AC3	914-016-0990	Hex socket (allen Key) & Domed Head bolt M4 x 15mm L x 0.7 pitch	Stainless Steel	-	2	Pcs	2
AC4	914-047-0009	Nyloc Nut : M4 x pitch 0.7 Stainless Steel	Stainless Steel	-	2	Pcs	2

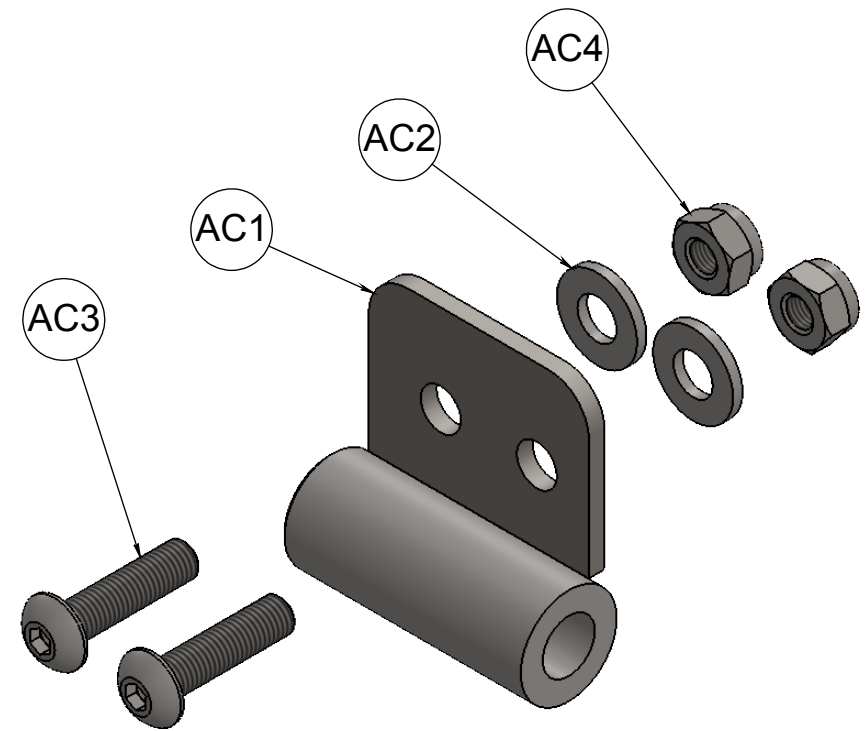
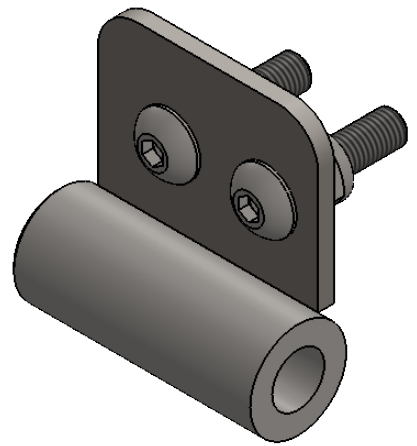

MO: 19110195	Batch:1 of 1	Product Description: Barrel Hinge Female Part (S-Steel) Bolt on RH	0	14-12-2019	AS PER CLIENT'S REQUEST					V1422			
Quantity Batch: 10		Product Code: 001-005-0037NZ	PRO REV.	DATE	ALTERATION					AUTH.			
Contract #: N/A		Dwg Description: LIST OF MATERIAL	Selection	0.5-3	>3-6	>6-30	>30-120	>120-400	>400-1000	>1000-2000	>2000-4000	>4000-8000	Angle Tolerance
Contract Ref: Reid&Twiname - C52		Client: Reid&Twiname		±0.05	±0.05	±0.1	±0.15	±0.2	±0.3	±0.5	±0.8	-	±1°
Issued By:	Date:	Client Dwg Ref: N/A	Client Rev: 0	±0.1	±0.1	±0.2	±0.3	±0.5	±0.8	±1.2	±2	±3	
Received By:	Date:	Product Finish: MATTE	→	±0.15	±0.2	±0.5	±0.8	±1.2	±2	±3	±4	±5	
NOTE: All dimensions in mm (unless noted otherwise)					W = 0.0 (Kg)			Sheet 2 of 3			First Angle Projection		

List of Part							
Part #	Code	Description	Material Spec	Size	Qty.	Unit	Total
AC1	SFP-010-0167	Barrel Hinge Female Part (S-Steel) Bolt on RH	S-Steel	-	1	Pcs	1

① LẤY TỪ KHO

⇒ ĐÓNG GÓI

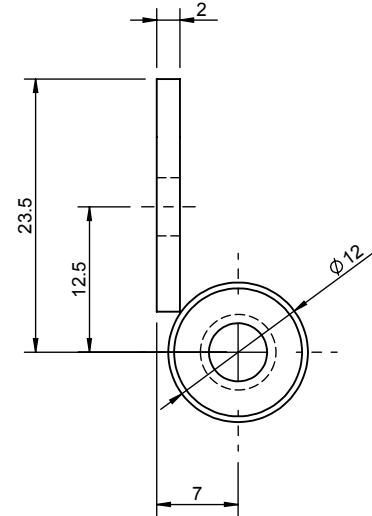
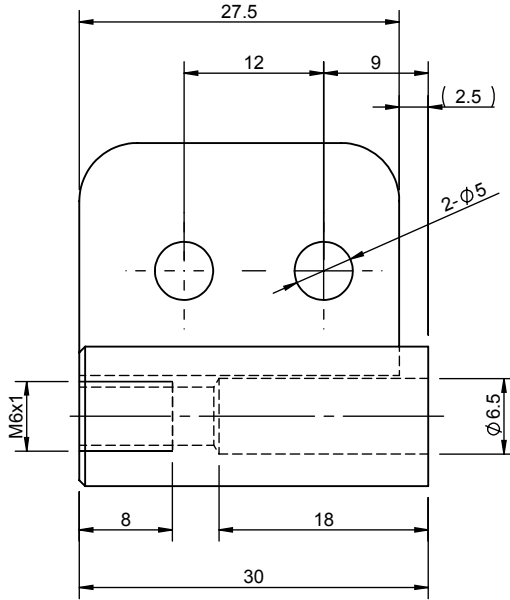
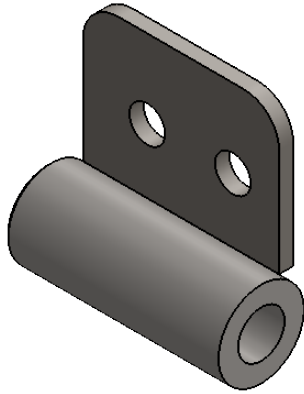

Yêu cầu/hướng dẫn

-
-

Xác nhận của người thực hiện:
 Các yêu cầu phía trên đã được thực hiện.

Ký tên - Mã số - Ngày thực hiện
 / /

Tên và Mã Số Máy: (Name & Machine's Code)		Mã Số Đồ Gá Kiểm Tra: (Check Jig's Code)	Dụng Cụ Kiểm Tra: (Check Tool)	Người Kiểm tra: (Checked By)	Ngày:..... (Date)	Người Thẩm Tra: (Verified By)	Ngày:..... (Date)							
Mã Số Dụng Cụ: (Tool's Code)		Mã Số Đồ Gá Lắp Ráp: (Assembly Jig's Code)	Tần Suất Kiểm Tra: (Check Frequency)											
MO: 19110195	Batch: 1 of 1	Product Description: Barrel Hinge Female Part (S-Steel) Bolt on RH		0	14-12-2019	AS PER CLIENT'S REQUEST		V1422						
Quantity Batch: 10		Product Code: 001-005-0037NZ		PRO REV.	DATE	ALTERATION		AUTH.						
Contract #: N/A		Dwg Description: AC01(1/2)		Selection	0.5-3	>3-6	>6-30	>30-120	>120-400	>400-1000	>1000-2000	>2000-4000	>4000-8000	Angle Tolerance
Contract Ref: Reid&Twname - C52		Client: Reid&Twname			±0.05	±0.05	±0.1	±0.15	±0.2	±0.3	±0.5	±0.8	-	±1°
Issued By:		Client Dwg Ref: N/A			±0.1	±0.1	±0.2	±0.3	±0.5	±0.8	±1.2	±2	±3	
Date:		Client Rev: 0		→	±0.15	±0.2	±0.5	±0.8	±1.2	±2	±3	±4	±5	
Received By:		Date:		Product Finish: MATTE		NOTE: All dimensions in mm (unless noted otherwise)		W = 0.03 (Kg)		Sheet 3 of 3		First Angle Projection		